

Factors Influencing Intelligent Construction Adoption Intention in the Construction Industry A SEM Approach

Hsing-Wei Tai¹, Yan-Fei Wang^{1,*}, Pang-Jui Tai², Chia-Chen Wei²

1. School of Architecture and Civil Engineering, Guangzhou Institute of Science and Technology,
Guangzhou, 510540, China

2. Department of Civil Engineering, Pingtung University of Science and Technology, Pingtung, 912301,
China

Abstract: In recent years, the global construction industry has been experiencing a new wave of technological innovation, with developed countries increasingly leveraging artificial intelligence (AI) as a key enabler to enhance their competitiveness in the sector. Against this backdrop, intelligent construction, as a product of the deep integration of new-generation information technologies and modern building industrialization, has emerged as the core engine and an inevitable path for driving the industry's transformation and upgrading. As a core driver of this transformation, the intention to adopt intelligent construction is pivotal to the success of the construction industry's transition. This study focuses on analyzing the adoption intention of the building construction industry towards intelligent construction. Utilizing the AMOS-based Structural Equation Model (SEM), with a focus on the usage intention and acceptance level within the building construction industry, this research investigates the key influencing factors for the implementation of intelligent construction in this field. Furthermore, SPSS software was employed to conduct reliability and validity analyses to examine the differential impacts of each factor. This study aims to provide a valuable reference for the large-scale application of intelligent construction in the building construction industry.

Keywords: Intelligent Construction; Structural Equation Model (SEM); Reliability Analysis; Artificial Intelligence (AI)

Currently, the traditional building construction industry struggles to adapt to the higher standards and diverse demands of the new era. The construction industry is undergoing a profound transformation centered on intelligent construction. The deep integration of information technology, industrialized construction technology, and advanced manufacturing technology has given rise to a new paradigm for engineering construction. Promoting intelligent construction can drive the construction industry towards greater efficiency, greenness, and intelligence, making it an inevitable choice for achieving sustainable development in the sector.

This study identifies the influencing factors of intelligent construction adoption intention primarily in the following aspects: *Technology Adoption Intention, Organizational Support, Workforce Capability Maturity, Data and Information Integration, and Intelligent Construction Performance*. By analyzing variable correlations through a Structural Equation Model (SEM), this research precisely dissects the core factors influencing the intention to adopt intelligent construction, thereby providing a theoretical basis for

the building construction industry to enhance its willingness to adopt intelligent construction.

1 Methodology

This paper identified five variables based on a literature review. All variables were measured using a 5-point Likert scale. Data were collected via a questionnaire survey method, on which descriptive statistical analysis was performed, and a Structural Equation Model (SEM) of intelligent construction adoption intention was constructed.

The Structural Equation Model (SEM), also known as the Linear Structural Relations Model, was proposed in the 1970s. It is a comprehensive statistical analysis method that integrates factor analysis and path analysis^[1, 2]. It has now been widely applied in the field of social sciences and is regarded as one of the three major advances in statistics in recent years^[3]. The relationships between variables are examined through the reliability and validity tests of the measurement model and the verification of path relationships in the structural model. Path analysis is then used to explore the relationships among latent variables.

1.1 Measurement Scale Design

The research model in this study comprises five variables. Nunnally pointed out that measuring a variable requires more than three indicators to ensure the validity of the measurement scale^[4]. In this study, except for the 'Intelligent Construction Performance' variable which uses six indicators, the other four variables each use five indicators.

1.2 Questionnaire Design and Collection

This questionnaire consists of three parts: the purpose of the survey, the respondents' personal information, and the measurement scales. Reliability analysis is an indispensable part in the research of data derived from questionnaire surveys. It allows questionnaire designers to preliminarily understand whether the designed questionnaire is a valid measurement instrument, so as to decide whether the questionnaire should be redesigned^[5]. It was distributed to selected construction enterprises in Shandong Province. A total of 240 questionnaires were distributed, and 186 were collected, resulting in a response rate of 77.5%. After screening, a total of 172 questionnaires were deemed valid, giving an effective response rate of 92.5%.

2 Results and Analysis

2.1 Descriptive Statistical Analysis

The descriptive analysis of intelligent construction revealed an overall positive attitude, with all core variables at a moderately high level. Among them, the mean value of Technology Adoption Intention was 3.902, Organizational Support was 3.964, Workforce Capability Maturity was 3.994, Data and Information Integration was 3.884, and Intelligent Construction Performance was 3.897. However, to translate this positive attitude into actual actions, improvements are still needed in areas such as employee motivation, practical operation skills training, and efficiency enhancement.

The samples were sorted by their scores and divided into two groups: the low-score group was coded as 1, and the high-score group was coded as 2. An independent samples t-test was conducted on these groups. For all tested variables, the degree of data fluctuation differed between the two groups, indicating unequal

variances. The significance values (p-values) of the t-tests for all variables were less than 0.05, indicating that there are indeed significant differences between the two groups in these aspects.

2.2 Reliability Analysis

The structural equation model in this study is shown in Figure 1. After testing the feasibility and appropriateness of individual measurement items in the questionnaire scale, it is necessary to examine the stability, consistency, and reliability of the entire measurement scale or each measurement dimension composed of these items, which is known as the reliability test. The most commonly used method for reliability testing is the Cronbach's Alpha reliability coefficient method. For the assessment of reliability, this study refers to Feng Yansong's reliability coefficient table^[4] and adopts a criterion that the Cronbach's Alpha coefficient for sub-scales should be greater than 0.7, with the reference standard for the overall scale being a Cronbach's Alpha coefficient greater than 0.8. For the evaluation standard of CITC (Corrected Item-Total Correlation), this study adopts a criterion that the CITC value should be greater than 0.5.

The Cronbach's Alpha value for the overall scale was 0.964, which is greater than 0.8. The results of the independent-samples t-test and reliability analysis are shown in Table 1. The Cronbach's Alpha values for the sub-scales were 0.789 for Technology Adoption Intention, 0.710 for Organizational Support, 0.838 for Workforce Capability Maturity, 0.746 for Data and Information Integration, and 0.896 for Intelligent Construction Performance. Overall, these values meet the criteria. However, the CITC value of OS1 was below 0.5, so this indicator was removed. After removing OS1, the Cronbach's Alpha value for Organizational Support became 0.780. In the Workforce Capability Maturity scale, although the CITC value of WCM4 was greater than 0.5, its removal led to an increase in the Cronbach's Alpha value, thus optimizing the scale quality.

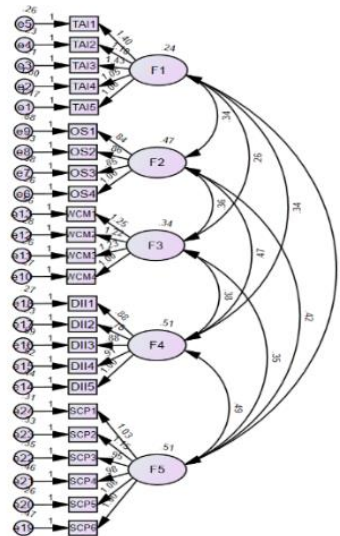

Fig 1. Structural Equation Model

2.3 Validity Analysis

The KMO value of the scale was 0.934, and the significance p-value of Bartlett's Test of Sphericity was

0.000. This indicates that the research variables are highly correlated, and factor analysis can be performed.

Table 1 Independent-Samples T-Test and Reliability Analysis

Variable	Item	Significance	Initial Cronbach's α	Deleted Item	Revised Cronbach's α
TAI	TAI1–TAI5	0.000	0.789	None	0.789
OS	OS1–OS5	0.000	0.710	OS1	0.780
WCM	WCM1–WCM5	0.000	0.838	WCM4	0.843
DII	DII1–DII5	0.000	0.846	None	0.846
SCP	SCP1–SCP6	0.000	0.896	None	0.896

A number of evaluation indices were employed, including the Chi-square/df ratio (χ^2/df), RMSEA, GFI, IFI, and CFI. The fitting indices are shown in Table 2. In this study, the χ^2/df value was 2.972 (less than 3), the RMSEA value was 0.066 (less than 0.08), the CFI value was 0.837, the IFI value was 0.836, and the GFI value was 0.801, all of which are greater than 0.8. Additionally, the PNFI value was 0.532 and the PCFI value was 0.533, both of which are greater than 0.5. These results indicate that the model fits well. The criterion for satisfactory convergent validity is that the factor loadings should be greater than 0.7^[6], while some researchers suggest that factor loadings above 0.5^[7] are also acceptable.

Table 2 Fit Indices

χ^2/df	RMSEA	CFI	IFI	GFI	PNFI	PCFI
2.972	0.066	0.837	0.836	0.801	0.532	0.533

3 Conclusion

Through empirical data collection via questionnaire surveys, and after completing initial model tests, problem diagnosis, model modifications, and full-dimensional hypothesis verifications, this study finally reveals the core driving mechanism and transmission path of the intention to adopt intelligent construction technology. Combined with the empirical results, targeted promotion strategies are proposed, and all research hypotheses have been effectively verified. The main conclusions are as follows: The core variables all have a significant positive direct impact on the intention to adopt intelligent construction technology, and there are differences in the intensity of their impact. Intelligent construction performance plays a significant partial mediating role between the core driving variables and the technology adoption intention, acting as a key transmission link.

4 Countermeasures and Suggestions

According to this study, the enhancement of adoption intention toward intelligent construction in the housing construction industry is affected by multiple factors. Among these, organizational support exerts a particularly significant impact on the adoption intention of intelligent construction. To improve the adoption

intention of intelligent construction, enterprises should reasonably increase investment in resources including funds, equipment, and talents related to intelligent construction in accordance with their own scale and development requirements.

Furthermore, enterprises should incorporate the advice of technical professionals, identify practical issues and application needs in the implementation of intelligent construction, and purposefully improve the adoption intention of technical personnel with regard to intelligent construction.

References

- [1] Na S, Heo S, Han S, et al. Acceptance model of artificial intelligence (AI)-based technologies in construction firms: Applying the Technology Acceptance Model (TAM) in combination with the Technology-Organisation-Environment (TOE) framework[J]. Buildings, 2022, 12(2):90.
- [2] Wu, M. L. Structural Equation Model: Operation and Application of AMOS (2nd ed.)[M]. Chongqing: Chongqing University Press, 2010.
- [3] Joreskog, Karl G. A general approach to confirmatory maximum likelihood factor analysis[J]. Psychometrika, 1969, 34.
- [4] Nunnally J. Psychometric theory[M]. New York: McGraw- Hill, 1978.
- [5] Zhang, H., Tian, M. F. Application of Reliability Analysis in Questionnaire Design[J]. Statistics & Decision, 2007(21):27-29.
- [6] Hair J, Anderson R E, Tatham R L, et al. Multivariate Data Analysis[M]. Prentice-Hall, Upper Saddle Rive, 1998.
- [7] Tabachnick B G, Fidell L S. Using Multivariate Statistics (5th Ed.)[M]. Pearson/Allyn & Bacon, 2007.

¹ **第 1 作者简介:** 戴兴伟 (1976-), 男, 广州理工学院, 教授, 研究方向: 工程管理, 可持续性发展, 智能建造, 智慧建筑。E-mail: rt007204@gmail.com。

* **通讯作者简介:** 王艳菲 (2004-), 女, 潍坊科技学院, 本科生, 研究方向: 工程管理。E-mail: 2376534466@qq.com。